

Prepaid Energy Meter for Billing System Using Microcontroller and Recharge Card

Sapna Ganurkar, Pravesh Gour

ABSTRACT

In this paper, the idea of a Prepaid energy meter using an AT89S52 microcontroller has been introduced. This concept provides a cost efficient manner of electricity billing. The present energy billing systems are discrete, inaccurate, costly and slow. They are also time and labour consuming. The major drawback of traditional billing system is power and energy theft. This drawback is reduced by using a prepaid energy meter which is based on the concept “Pay first and then use it”. Prepaid energy meter also reduces the error made by humans while taking readings to a large extent and there is no need to take reading in it. The prepaid energy meter uses a recharge card which is available in various ranges (i.e. Rs. 50, Rs. 100, Rs. 200, etc.). The recharge is done by using a keypad and the meter is charged with the amount. According to the power consumption, the amount will be reduced. An LDR (light Dependant Resistor) circuit counts the amount of energy consumed and displays the remaining amount of energy on the LCD. A relay system has been used which shut down or disconnect the energy meter and load through supply mains when the recharge amount is depleted. A buzzer is used as an alarm which starts before the recharge amount reaches a minimum value.

Keywords: - AT89S52 microcontroller, AT24C02 microcontroller, ULN2003, relay, LDR, energy meter.

I. INTRODUCTION

The present traditional billing system have many problems like problem of payment collection, energy thefts etc. due to which the traditional billing system is slow, costly and unreliable[1]. The present billing system has chances of error and it is also time or labour consuming. A paper suggests a design of digital energy meter for improved metering and billing system [2]. Poly-phase prepaid energy metering system has also been proposed and developed based on local prepayment and card reader [3]. Another paper suggests prepaid energy meter using a microcontroller from microchip technology Inc PIC family, used due to low cost of microcontrollers[4]. So it is essential to develop a billing system which solves the problem of billing manually and also reduces the manpower.

In this paper we proposed and designed a prepaid energy meter using two microcontrollers AT89S52 and AT24C02 from ATMEL family. The reason for using these microcontrollers is its high performance, power efficiency or design flexibility etc. In this paper, a recharge card is used which is available in various ranges (i.e. Rs. 50, Rs. 100, Rs. 20 etc.) and the energy meter to which the no. of recharge units has to be loaded[5]. Suppose a

consumer buys a recharge card for Rs. 50 he/she can insert this amount through the keypad so that the prepaid energy meter will be activated. According to the power consumption the amount will be reduced.

An LDR circuit is used to count the amount of energy consumed and an LCD is used to display the meter readings. When the recharge card amount is nil the relay will automatically shut down the whole system. In this project we also have provision to give an alarm sound using buzzer to the consumer before the whole amount is depleted [6].

III.PREPAID ENERGY METER

Prepaid energy meter is technique which is cost efficient and can reduce problems associated with billing and also reduces deployment of manpower for taking meter readings. Prepaid energy meter has many advantages both from suppliers as well as consumer's point as follows:-

Why Prepayment – From supplier point of view?

- Pay before use
- Keep customers on supply
- Recover money owed (debt)
- Lower overhead
- No bill production
- No bill distribution
- No need to chase payments
- No further actions such as disconnections
- Social acceptability
- Customer responsible for disconnection
- Load and demand side management
- Limit load
- Load based
- Time based

Why Prepayment – From Customer point of view?

- >80% mobile phones used in India are prepaid
- Flexible payment solution
- Pay to suit your income status
- Daily, weekly , monthly budgeting
- Show true cost of consumption and money left

- Reduce consumption when income is tight– make money last
- Reduce waste – conserve energy
- No bills
- No billing errors
- No socially unacceptable disconnections.

A. Block Diagram of Prepaid Energy Meter

The block diagram of prepaid energy meter is shown in fig. (ii). It consist of microcontroller AT89S52, buzzer, keypad, relay, single phase energy meter, IC AT24C02 which is an EEPROM and has volatile memory, IC ULN2003 is a high voltage/ high current Darlington array each contains seven open collector Darlington pairs with common emitters used to drive loads.

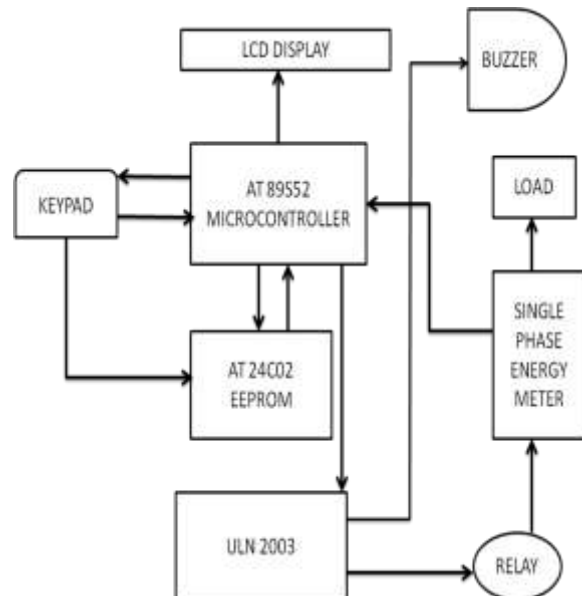

Fig.(ii) Block diagram of Prepaid energy meter

B. Circuit Description and working

The circuit diagram of prepaid energy meter contains two parts (a) energy meter circuit (Fig. iii)[6] (b) LDR circuit (Fig. iv).

(a) Energy Meter Circuit

The circuit diagram of energy meter circuit is shown in fig. (iii). A 230 V A.C – 12 V D.C step down

transformer is used as power supply. The rectifier circuit is used to convert A.C into D.C. at the output of rectifier circuit +12V power supply is generated. The IC 7805 is a voltage regulator which is a 3 pin IC and is used to convert +12V into +5V. Now in our project where we need +5V supply we take it from output of IC7805 and where we required +12V supply we take from the input of IC7805. When the microcontroller AT89S52[10] which is a 40 pin IC gets signals first of all we insert the recharge number using the keypad. The recharge unit is stored in IC AT24C02 which is an EEPROM and has volatile memory and this recharge unit is display in Liquid Crystal display (LCD) and a message “recharge successful” also displays. The IC ULN2003 is a high voltage/ high current Darlington array containing seven open collector Darlington pairs with common emitters used to drive loads. Since the current produced by the microcontroller is only 10 mA which is very low to drive a relay that is why we are using ULN2003[11] which converts 10 mA into 80 mA and the relay is switched ON. As the power is consumed the reading in the single phase energy meter(connected across X2-1 and X2-2) is increased and the units in LCD is decreased by Rs.1. When the balance reaches to Rs.10 then the buzzer starts indicating that we should recharge our meter soon. And if balance is nil then the relay is switched off and no electricity flows.

(b) LDR Circuit

LDRs or Light Dependent Resistors are very useful especially in light/dark sensor circuits [12]. Normally the resistance of an LDR is very high, sometimes as high as 10 MΩ, but when they are illuminated with light resistance drops dramatically. When the light level is low the resistance of the LDR is high. This prevents current from flowing to the 555 timer. Consequently the LED does not light. However, when light shines onto the LDR its resistance falls and current flows into the 555 timer and the LED lights. LDR Circuit is used to count the unit pulses. When the LED blinks for 10 time it counts the energy unit as 1. This will show in LCD of the main circuit and the recharge amount in the LCD is decreased by Rs.1.

C. Energy calculation

Energy is the measure of how much work has been required over a known period of time. We are using a light bulb as a load with a 100W rating which consumes 100 watts of active power in order to create light (and heat)[2]. First of all a wattmeter is used to measure the power consumed by the load by using the equation. The frequency across 100 W load obtained during an experiment is $F= 0.5 \text{ Hz}$

$$\text{And } P = 100 * X / 0.5$$

$$P = 200 * X$$

Where X is the frequency of pulses that is produced by the energy meter.

$$1 \text{ watt sec} = 1 \text{ kW sec} / 1000$$

$$1 \text{ watt sec} = 1 \text{ kWh} / (1000 * 3600)$$

$$\text{Therefore Energy} = P * \text{Sec} / (1000 * 3600)$$

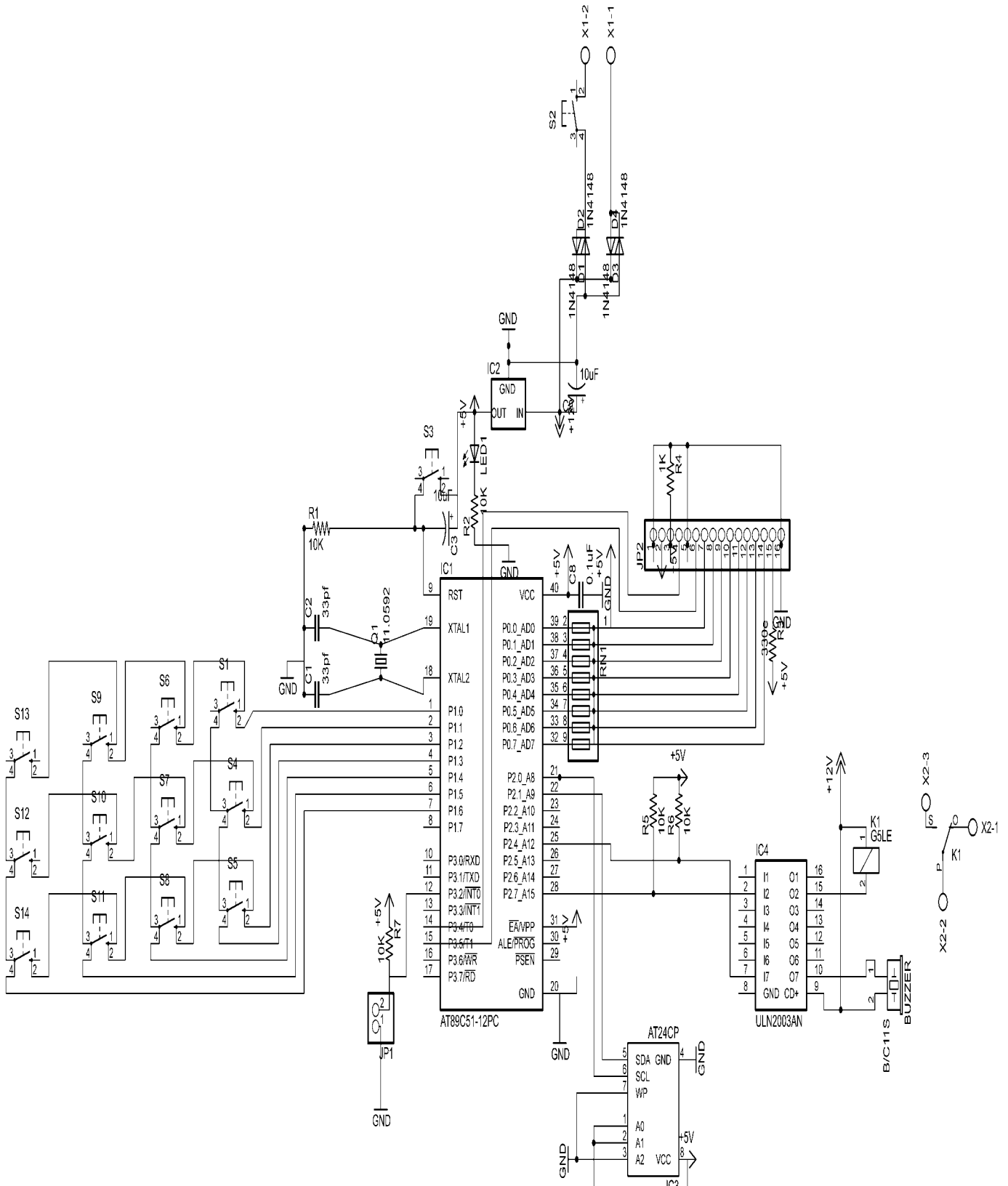

Fig.(iii) Energy Meter Circuit Diagram

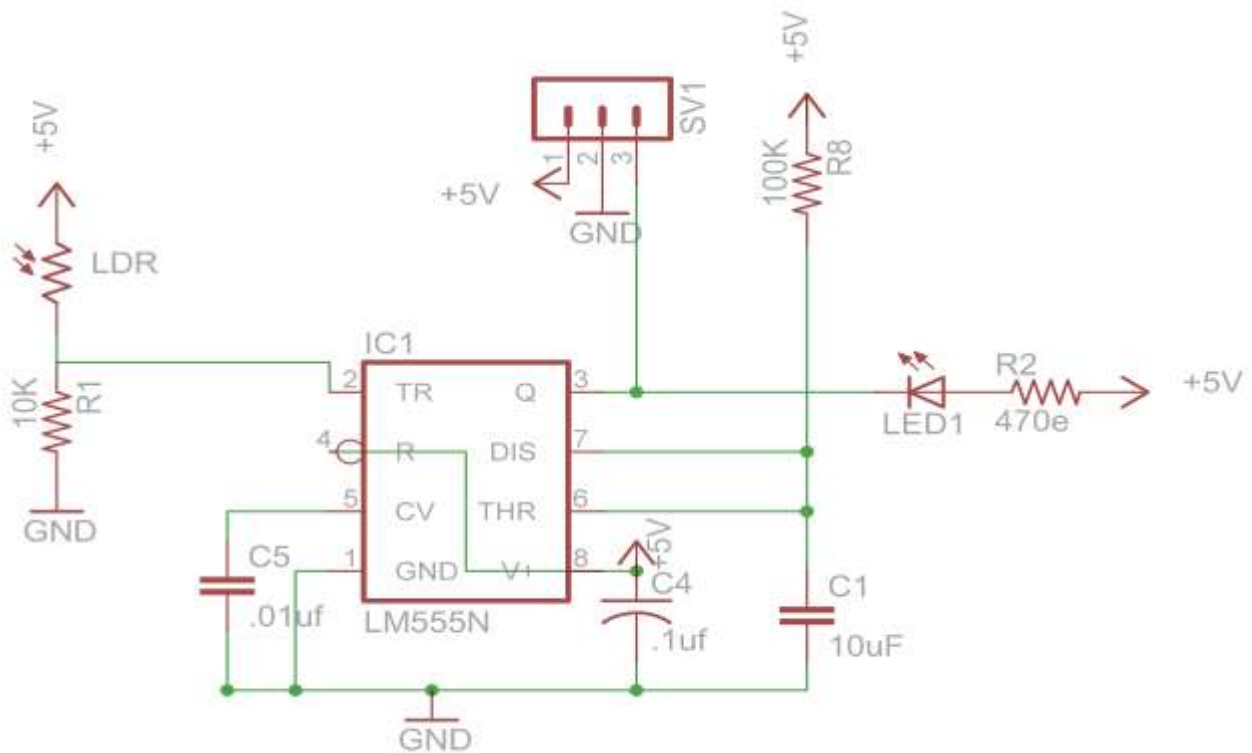

Fig.(iv) LDR Circuit

Table 1. Test result of prepaid energy meter

Time (sec)	Energy Output from Measurement (kW-sec)
0	0
10	0.27
20	0.55
30	0.83
40	1.11
50	1.38

60	1.66
70	1.94
80	2.22
90	2.50
100	2.77
110	3.04
120	3.32

D. Software development for prepaid energy meter

The system software is implemented by C[14] language and the developed code is edited, compiled and debugging by Win-AVR software. We can also program the system using MATLAB [13].

IV. RESULT

The energy meter was tested by using an electric light bulb of 100 watts that draws current up to A. The supply voltage was 230 V. First of all a wattmeter was used to measure the power consumed by the load. Then energy consumption was measured after every 10 seconds. Total 5 pulses occurred at every 10 seconds in energy meter. The computed energy consumption is read from the LCD. The result is shown in Table 1. The test was done over a 2 minute period and measurements were taken every 10 seconds [2].

V.CONCLUSION

The paper is intended to present an overview of prepaid energy meter, which can control the usage of electricity on consumer side to avoid wastage of power. Prepaid energy meter is a concept to minimize the Electricity theft with a cost efficient manner.

1. The users are not bound to pay excesses amount of money, users have to pay according to their requirement.
2. It can reduce problems associated with billing consumers living in isolated areas

and reduce deployment of manpower for taking meter readings.

3. Prepaid energy meter is more reliable and user friendly.

From all these we can conclude that if we implement this prepaid energy meter then it can become more beneficial.

REFERENCES

- [1] Devidas, A.R., Ramesh, M.V. "Wireless Smart Grid Design for Monitoring and Optimizing Electric Transmission in India," 2010 Fourth International Conference on Sensor Technologies and Applications (SENSORCOMM)," pp.637-640, 2010
- [2] Md. Mejbaul Haque "Microcontroller Based Single Phase Digital Prepaid Energy Meter for Improved Metering" International Journal of Power Electronics and Drive System (IJPEDS) December 2011, pp. 139~147
- [3] Ling Zou, Sihong Chu and Biao Guo., "The Design of Prepayment Polyphase Smart Electricity Meter System," International Conference on Intelligent Computing and Integrated Systems (ICISS), pp. 430-432, 22-24, Dec 2010.
- [4] Loss, P et al., "A Single Phase Microcontroller Based Energy Meter," IEEE Instrumentation and Measurement Technology Conference. St. Paul Minnesota, USA, May 18-21, 1998
- [5] www.8051projects.net/download-d134-prepaid-energy-meter-at89s52

[6] Prepaid Energy Meter (AT89S52)
8051 Microcontroller indianengineer.
wordpress.com/.../prepaid-energy-meter at89s52.

[7] Mazidi. Mohammed Ali and Janice Gillespie
Mazidi. “The 8051 microcontroller
and embedded systems”, second edition, Prentice
Hall Publications, 1999.

[8] Irfan Quazi, Sachin Kumar Gupta, Rajendra
Prasad, “Pre-paid Energy Meter based on AVR
Microcontroller / International Journal of
Engineering Research and Applications (IJERA)

[9] Atmel Corporation - Atmel AT89S52 8- and 32-
bit Microcontrollers
<http://www.atmel.com/products/AT89S52/>

[10] Atmel AT89S52 Data Sheet

[http://www.keil.com/dd/docs/datashts/atmel/at89s52_](http://www.keil.com/dd/docs/datashts/atmel/at89s52_ds.pdf)
[ds.pdf](http://www.keil.com/dd/docs/datashts/atmel/at89s52_ds.pdf)

[11] IC ULN2003, AT24C02
www.alldatasheet.com/datasheet-pdf/

[12]LDR
<http://www.technologystudent.com/elec1/ldr1.htm>

[13] Amit Jain¹, Mohnish Bagree², “A prepaid meter
using mobile communication” *Power Systems
Research Center, International Institute of
Information Technology, Hyderabad, INDIA.*
*School of Electrical Engineering, Vellore Institute
of Technology, Vellore, INDIA*

[14] “Let Us C” by Yashwant Kanetkar.

Sapna Ganurkar

Department of Electronics & Communication
Institute of Engineering and Technology
Indore, Madhya Pradesh (India)
Email: sapnaganurkar@gmail.com

Pravesh Gour

Network Infrastructure Engineer,
Tulip Telecom Ltd.,
Indore, Madhya Pradesh (India)
Email: praveshgr@gmail.com