

A NOVEL FUEL CELL BASED BUCK-BOOST VOLTAGE/CURRENT SOURCE INVERTER USING SVPWAM CONTROL SCHEME

B Rambabu¹, Lakshmi prasad Jakka², A Venkata prasad³, T Manohar⁴

*Asst. Professor: department of EEE, Anantha Lakshmi Institute of technology and sciences,
Anantapur, India¹*

*Asst. Professor: department of EEE, Anantha Lakshmi Institute of technology
and sciences, Anantapur, India²*

*Asst. Professor: department of EEE, Anantha Lakshmi Institute of technology and
sciences, Anantapur, India³*

*Asst. Professor: department of EEE, Anantha Lakshmi Institute of technology and
sciences, Anantapur, India⁴*

Abstract

This paper proposes a new Hybrid Electric Vehicle (HEV) which works with Fuel Cell and battery based on Buck-Boost Voltage/Current Source Inverter using Space Vector Pulse Width Amplitude Modulation (SVPWAM) technique. It mainly focuses on control technique for an VSI/CSI. The switching losses are reduced by 87% for VSI, 60% for CSI with SVPWAM technique compared to conventional Sinusoidal PWM technique. In both cases power density is increased by 2 to 3 times. It is also verified that the output harmonic distortions of SVPWAM is lower than SPWM, by using only one third of switching frequency of latter one. It is obtained that it is feasible to use SVPWAM to make the buck-boost inverter suitable for applications that require high efficiency, high power density, high temperature, and low cost the simulation results are carried out for which the result shows its reliability and performance.

I. INTRODUCTION

In recent years, Fuel Cell (FC) systems have received unprecedented attention due to the concerns about adverse effects of extensive use of fossil fuels on the environment and energy security. Also, these have got more attention in Electric vehicles. Currently, two existing inverter topologies are used for electric vehicles (EVs), they are the conventional three-phase inverter with a high voltage battery and a three-phase pulse width modulation (PWM) inverter with a dc/dc boost front end. The conventional PWM inverter imposes high stress on switching devices and motor thus limits the motor's constant power speed range (CPSR), which can be overcome through the dc-dc boosted PWM inverter.

A typical configuration of the Solar Hybrid electric vehicle (SHEV) is shown in Fig. 1. The inverter is required to inject low harmonic current to the motor, in order to reduce the winding loss and core loss. For this purpose, the switching frequency of the inverter is designed within a high range from 15 to 20 kHz, resulting in the switching loss increase in switching device and also the core

loss increase in the motor stator. To solve this problem, various soft-switching methods have been proposed [1]-[3]. Active switching rectifier or a diode rectifier with small DC link capacitor has been proposed in [4], [5], [8]-[12].

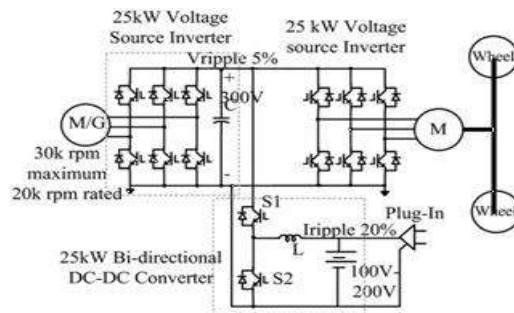

Fig 1 Typical configuration of a Fuel Cell HEV

Various types of modulation methods such as optimized pulse-width-modulation [13], improved Space-Vector-PWM control for different optimization targets and applications [14]-[16], and discontinuous PWM (DPWM) [17] have been proposed previously. Different switching sequence arrangement can also affect the harmonics, power loss and voltage/current ripples [18]. DPWM has been widely used to reduce the switching frequency, by selecting only one zero vector in one sector. It results in 50% switching frequency reduction. However, if an equal output THD is required, DPWM cannot reduce switching loss than SPWM. Moreover, it will worsen the device heat transfer because of the temperature variation.

A double 120 flat-top modulation method has been proposed in [6] and [7] to reduce the period of PWM switching to only 1/3 of the whole fundamental period. However, these papers didn't compare the spectrum of this method with others, which is not fair. In addition, the method is only specified to a fixed topology, which cannot be applied widely. This paper proposes a novel generalized space vector pulse width amplitude modulation (SVPWAM) method for the buck/boost voltage source inverter (VSI) and current source inverter (CSI). By eliminating the conventional zero vector in the space vector modulation, two-third and one-third switching frequency reduction can be achieved in VSI and CSI, respectively. If a unity power factor is assumed, an 87% switching loss reduction can be implemented in VSI, and a 74% reduction can be implemented in CSI. Therefore, a high-efficiency, high-power density, high-temperature, and low-cost inverter is achieved by using an SVPWAM method. In each sector, only one phase leg is doing PWM switching; thus, the switching frequency is reduced by two-third. This imposes zero switching for one phase leg in the adjacent two sectors. For example, in sector VI and I, phase leg A has no switching at all. The dc-link voltage thus is directly generated from the output line-to-line voltage.

II. PEM FUEL CELL MODEL

A fuel cell is a static energy conversion device that converts chemical reaction of fuels directly into electrical energy with some heat and produces water as its byproduct [13]. The chemical reaction sustains as long as fuel and oxidant supply is maintained. Fig. 1 shows a simple arrangement of fuel cell system. The chemical reaction involved in the anode, cathode and electrolyte membrane for the production of electricity is given below:

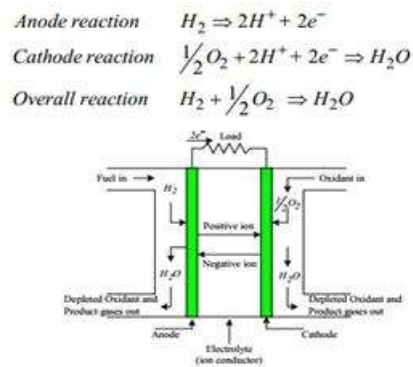

Fig.2. Fuel cell operation diagram.

The fuel cell performance is earmarked by its thermal and electrical efficiency. The thermodynamic efficiency depends on fuel processing, water management and temperature control of the system. The electrical efficiency of the fuel cell depends on the activation & concentration loss apart from natural Ohmic loss.

$$V_{dc_stack} = V_{open} - V_{ohmic} - V_{act} - V_{con}$$

$$V_{open} = N_e \left[V_o + \frac{RT}{2F} \ln \left(\frac{PH_2 \sqrt{PO_2}}{PH_2O \sqrt{PO}} \right) \right]$$

$$V_{ohmic} = I_{dc} \cdot R_{FC}$$

$$V_{act} = N_e \cdot \frac{RT}{2\alpha F} \cdot \ln \left(\frac{I_{dc}}{I_0} \right)$$

$$V_{con} = -c \cdot \ln \left(1 - \frac{I_{dc}}{I_{Lim}} \right)$$

Figure shows the simulink model as developed for the fuel cell stack based on the above five equations. The simulated I-V characteristics of PEM fuel cell stack voltage for the fixed values of input fuel pressures for single cell is shown in Fig. 3. It can be seen that at low current level, the ohmic loss becomes less significant and the increase in output voltage is mainly due to activity of slowness of chemical reactions. So this region is also called active-polarization. At very high current density the voltage fall down significantly because of the reduction of gas exchange efficiency. This is mainly due to over flooding of water in catalyst and this region is also called concentration polarization. Intermediate between the active region and concentrations region there is a linear slope which is mainly due to internal resistance offered by various components of the fuel cell. This region is generally called as ohmic region.

III.VSI EMPLOYING SVPWAM:

A.SVPWAM Control Principle in VSI :

The principle of an SVPWAM control is to eliminate the zero vectors in each sector. The modulation principle of SVPWAM is shown in Figure. DC link capacitor have been proposed in [4], [5], [8]-[12].Varies types of modulation method have been proposed previously such as optimized pulse-width-modulation [13], improved-Space-Vector-PWM control for different optimization targets and applications [14]-[16], and discontinuous PWM (DPWM)[17]. Different switching sequence arrangement can also affect the harmonics, power loss and voltage/current ripples [18].DPWM has been widely used to reduce the switching frequency, by selecting only one zero

vector in one sector. It results in 50% switching frequency reduction. However, if an equal output THD is required, DPWM can not reduce switching loss than SPWM. More-over, it will worsen the device heat transfer because the temperature variation. A double 120 flat top modulation-method has been proposed in [6] and [7] to reduce the period of PWM switching to only 1/3 of the whole fundamental period.

However, these papers didn't compare the spectrum of this method with others, which is not fair. In addition, the method is only specified to a fixed topology, which can not be applied widely. This paper proposes a novel general-ized space vector pulsewidth amplitude modulation (SVP-WAM) method for the buck/boost voltage source inverter (VSI) and current source inverter(CSI). By eliminating the conventional zero vector in the space vector modulation, two-third and one-third switching frequency reduction can be achieved in VSI and CSI, respectively.

If a unity power factor is assumed, an 87% switching loss reduction can be implemented in VSI, and a 74% reduction can be implemented in CSI. A 1-kW boost-converter inverter system has been developed and tested based on the SVPWAM method. A 90% power loss reduction compared to SPWM has been observed. The two stage efficiency reaches 96.7% at the full power rating. The power volume density of the prototype is 2.3 kW/L. The total weight of the system is 1.51 lb.

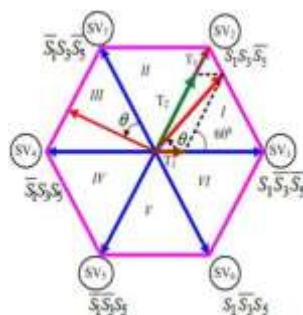

Fig. 3. SVPWAM for VSI.

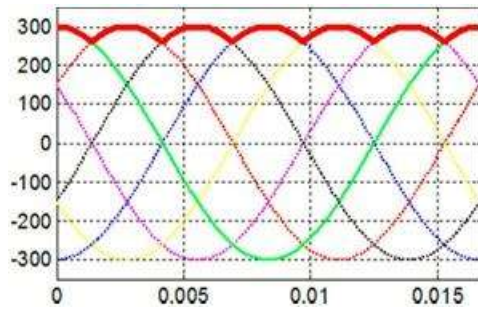

Fig. 4. DC-link voltage of SVPWAM in VSI.

Therefore, a high-efficiency, high-power density, high-temperature, and lowcost1-kW inverter is achieved by using an SVP-WAM method.

IV. SVPWAM FOR CSI:

A.Principle of SVPWAM in CSI:

The principle of SVPWAM in CSI is also to eliminate the zero-vectors. As shown in Fig, for each sector, only two switches are doing PWM switching, since only one switch in upper phase legs and one switch in lower phase legs are conducting together at any moment. Thus, for each switch, it only needs to do PWM.

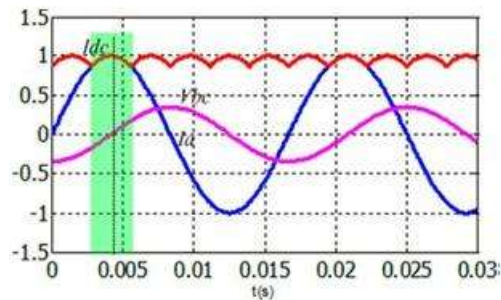

Fig. 5. Switching voltage and current when $pf = 1$.

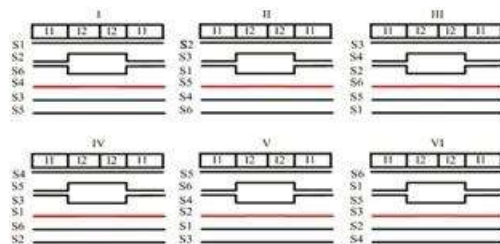

Fig. 6. Vector placement for each sector for CSI.

switching in two sectors, which is one-third of the switching period. Compared to SVPWM with

single zero vec-tor selected in each sector, this method brings down the switching frequency by one-third. Similarly, the dc-link current in this case is a 6ω varied current. It is the maximum envelope of six output currents: $I_a, I_b,$

$I_c, -I_a, -I_b, -I_c$, as shown in Fig. 8. For example, in sector I, S1 always keeps ON, so the dc-link current is equal to I_a . The difference between dc-link current in CSI and dc-link voltage in VSI is dc-link current in CSI is overlapped with the phase current, but dc-link voltage in VSI is overlapped with the line voltage, not the phase voltage. The time intervals for two adjacent vectors can be calculated in the same way as (1) and (2). According to diagram in Fig. 7, the vector placement in each switching cycle for six switches can be plotted in Fig. 9. The SVPWM is implemented on conventional CSI through simulation. Figure shows the ideal waveforms of the dc current I_{dc} , the output phase ac current and the switching signals of S1. The switching signal has two sections of PWM in positive cycle, but no PWM in negative cycle at all.

B. Inverter Switching Loss Reduction for CSI:

In CSI, the current stress on the switch is equal to the dc link current, and the voltage stress is equal to output line-to-line voltage, as shown the shadow area in Fig. Thus, the switching loss for a single switch is determined by

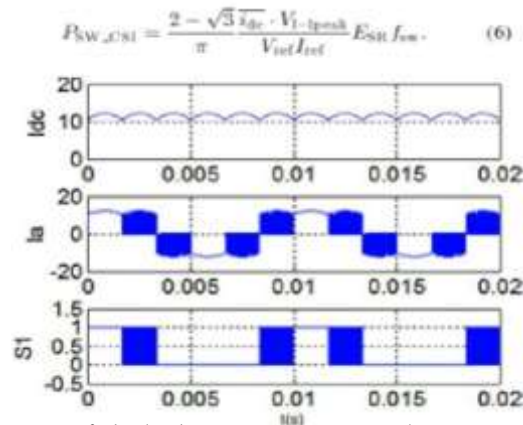

Fig. 7. Theoretic waveforms of dc-link current, output line current and switching signals.

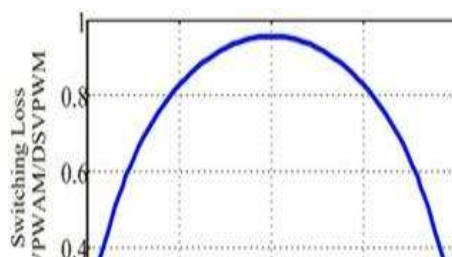

Fig. 8. CSI switching loss ratio between SVPWAM and discontinuouseSVPWM versus power factor.

When compared to discontinuousSVPWM,if the half switchingfrequency is utilized, then the switching loss of it becomeshalf of the result in (6). The corresponding switching loss ratiobetween SVPWAM and discontinuous SVPWM is shown inFig.

V. TOPOLOGIES FOR SVPWAM:

Basically, the topologies that can utilize SVPWAM have twostages: dc-dc conversion which converts a dc voltage or currentinto a 6ω varied dc-link voltage or current; VSI or CSI for whichSVPWAM is applied. One typical ex-ample of this structure isthe boost converter inverter dis-cussed previously. However, thesame function can also be implemented in a single stage, suchas Z/quasi-Z/trans-Z source inverter [37]-[40]. The front stage can also be in-tegrated with inverter to form a single stage. Take current-fed quasi-Z-source inverter as an

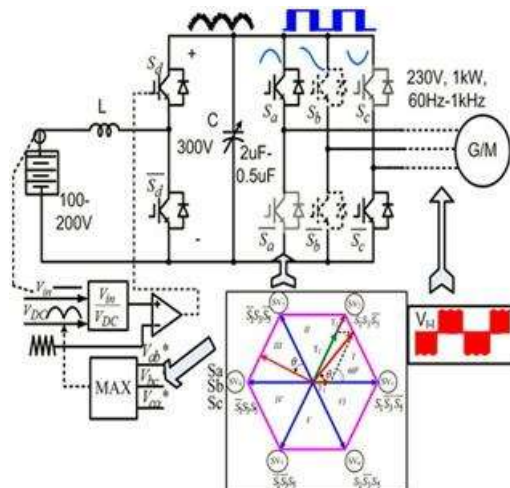

Fig. 9. SVPWAM-based boost-converter-inverter mo-tor drive system.

example. Instead of controlling the dc-link current I_{pn} to have a constant average value, the open zero state duty cycle D_{op} will be regulated instantaneously to control I_{pm} to have a 6ω fluctuate average value, resulting in a pulse type 6ω waveform at the real dc-link current I_{pn} , since I_1 is related to the input dc current I_{in} by a transfer function

$$I_1 = \frac{1 - D_{op}}{1 - 2D_{op}} I_{in} \quad (9)$$

VI.CASE STUDY: 1-KWBOOST-CON-VERTER INVERTER FOR EV MOTOR DRIVE APPLICATION:

A.Basic Control Principle:

The circuit schematic and control system for a 1-kW boostconverterinverter motor drive system is shown in

Fig. A6ω dc-link voltage is generated from a constant dc voltage by a boost converter, using open-loop control. Inverter then couldbe modulated by a SVPWAM meth-od. The specifications forthe system are input voltage is

100–200 V; the average dc-linkvoltage is 300 V; output line-to-line voltage rms is 230 V; andfrequency is from 60 Hz to 1 kHz.

B.Voltage Constraint and Operation Region:

It is worth noting that the SVPWAM technique can only be applied when the batteries voltage falls into the region

$$V_{in} \leq \frac{\sqrt{3}}{2} V_{L-L}$$

due to the step-up nature of boost converter.The con-straint is determined by the minimum point of the ωdc-link voltage. Beyond this region, conventional SPWM canbe implemented. However, the dc-link voltage in this case stillvaries with ω because of the small film capaci-tor we selected.Thus, a modified SPWM with varying dc-link voltage will beadopted during the motor start up as shown in Figure. Hence,the system will achieve optimum efficiency when the motor isoperating a little below or around nominal voltage. When themotor demands a low voltage during start up, efficiency is thesame as the con-ventional SPWM-controlled inverter.

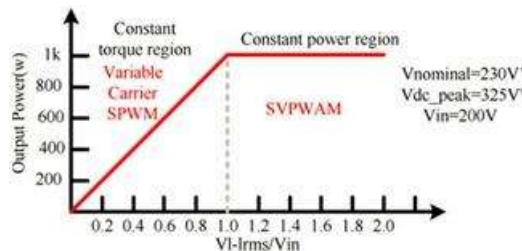

Fig. 10. Operation region of boost-converter-inverter EV traction drive

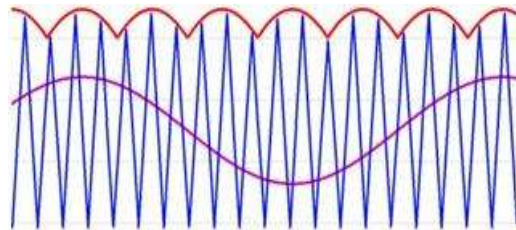

Fig.11.Variable carrier SPWM control in buck mode.

In SVPWAM control of boost mode, dc-link voltage varies with the output voltage, in which the modulation index is always kept maximum. So, when dc-link voltage is above the battery voltage, dc-link voltage level varies with the output voltage. The voltage utilization increased and the total power stress on the devices has been reduced.

C.Variable DC-Link SPWM Control at High

Frequency

When the output needs to operate at a relative high frequency, like between 120 Hz and 1 kHz, it is challenging to obtain a 6ω dc-link voltage without increasing the switching frequency of a boost converter. Because the controller does not have enough bandwidth. Furthermore, increasing boost converter switching frequency would cause a substantial increase of the total switching loss, because it takes up more than 75% of the total switching loss.

The reason is because it switches at a complete current region. Also a normal SPWM can not be used in this range because the capacitor is designed to be small that it can not hold a constant dc link voltage. Therefore, the optimum option is to control the dc link voltage to be 6ω and do a variable dc link SPWM modulation, as explained in Fig. In this variable dc-link SPWM control, in order to get better utilization of the dc-link voltage, an integer times between the dc-link fundamental frequency and output frequency is preferred. When the output frequency is in [60

Hz, 120 Hz], a 6ω dc link is chosen; when the frequency is in [120 Hz, 240 Hz], a 3ω dc link is chosen; when the

frequency is in [240 Hz, 360 Hz], a 2ω dc link is chosen

VII.Simulation Results

The parameters used in the test are rated power: 1 kW; battery voltage: 100–200 V; rated line voltage rms: 230 V; dc-link voltage peak: 324 V; switching frequency: 20 kHz;

output frequency: 60 Hz–1 kHz

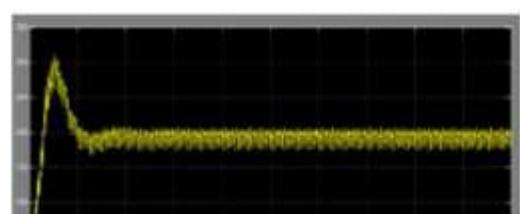
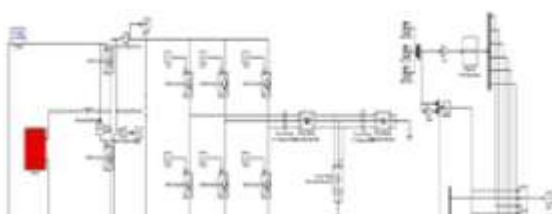

Fig.12. Fuel Cell based Simulation Circuit

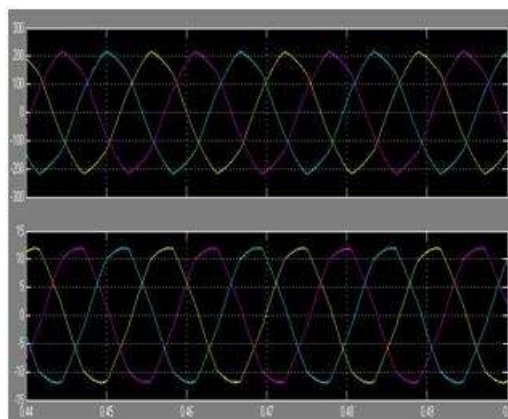

Fig.13 Load Voltage and Current

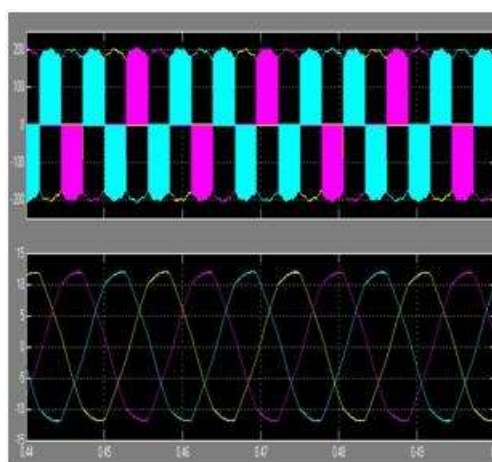

Fig.14 Inverter Output voltage and current

D. Overall Efficiency and Power Loss Comparison Between SVPWAM and SPWM

Fig. shows the measured efficiency when the input voltage increases from 100 to 200 V, all at 1-kW power rating. The overall efficiency increases as the input voltage increases, because the efficiency of a boost converter increases when the input voltage increases. The maximum efficiency at 1 kW reaches 96.7% at input voltage 200 V. It can be seen that the maximum efficiency at constant torque region happens at its maximum output voltage where the voltage.

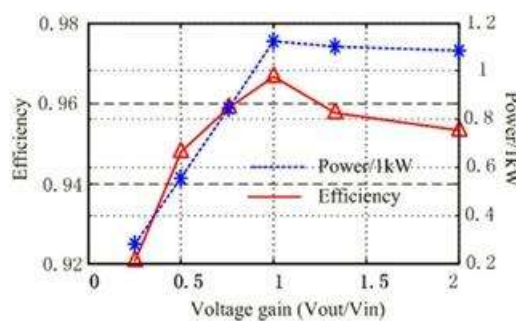

Fig.16 Efficiency versus voltage gain results corresponding to Fig. 19.

increases from 0 to full rating under two methods. Since the research target is only inverter, the test condition is based on varying the output power by changing output voltage from 0 to 230 V. It is observed that in the SVP-WAM method, conduction loss accounts for 80% of the total power loss, but in the SPWM method, switching loss is higher than conduction loss. The switching loss is reduced from 10 to 1.4 W from SPWM to SVPWAM. An estimated 87% switching loss reduction has been achieved.

VIII. CONCLUSION:

The SVPWAM control method preserves the following advantages compared to traditional SPWM and SVPWM method.

- 1) The switching power loss is reduced by 90% compared With the conventional SPWM inverter system.
- 2) The power density is increased by a factor of 2 because of reduced dc capacitor (from 40 to 6 μ F) and small heat-sink is needed.
- 3) The cost is reduced by 30% because of reduced passives, heat sink, and semiconductor stress.

A high-efficiency, high-power density, high-temperature, and low-cost 1-kW inverter engine drive system has been developed and tested. The effectiveness of the proposed method in reduction of power losses has been validated by the Simulation results that were obtained from the laboratory scale prototype.

REFERENCES

- [1] D. M. Divan and G. Skibinski, "Zero-switching-loss inverters for highpowerapplications," IEEE Trans. Ind. Appl., vol. 25, no. 4, pp. 634-643, Jul./ Aug. 1989.
- [2] W. McMurray, "Resonant snubbers with auxiliary switches," IEEE Trans. Ind. Appl., vol. 29, no. 2, pp. 355- 362, Mar./Apr. 1993.
- [3] J.-S. Lai, R. W. Young, Sr., G. W. Ott, Jr., J. W. McKeever, and F. Z. Peng, "A delta-configured auxiliary resonant snubber inverter," IEEE Trans. Ind. Appl., vol. 32, no. 3, pp. 518-525, May/ Jun. 1996.
- [4] J. S. Kim and S. K. Sul, "New control scheme for ac-dc-ac converter without dc link electrolytic capacitor," in Proc. 24th Annu. IEEE Power Electron. Spec. Conf., Jun. 1993, pp. 300-306.
- [5] K. Rigbers, S. Thomas, U. Boke, and R. W. De Doncker, "Behavior and loss modeling of a three-phase resonant pole inverter operating with 120° double flat top modulation," in Proc. 41st IAS Annu. Meeting IEEE Ind. Appl. Conf., Oct. 8-12, 2006, vol. 4, pp. 1694-1701.
- [6] J. Shen, K. Rigbers, C. P. Dick, and R. W. De Doncker, "A dynamic boost converter input stage for a double 120° flat top modulation based three phase inverter," in Proc. IEEE Ind. Appl. Soc. Annu. Meeting, Oct. 5-9, 2008, pp. 1-7.