

**DESIGN OF PHOTOVOLTAIC SYSTEM WITH MAXIMUM POWER POINT TRACKER
USING MODULAR MULTI LEVEL INVERTER**

#1BESTA SRUTHI, K SIVA KUMAR and B RAMESH BABU

¹Assistant Professor Dept of EEE,

²Assistant Professor Dept of EEE,

²Associate Professor and Head, Dept of EEE,

Bheema Institute of Technology and Science, Alur Road, Adoni, AP, India.

Abstract

This paper presents a modular cascaded H-bridge multilevel photovoltaic (PV) inverter for single or three phase grid connected applications with fuzzy logic controller. The modular cascaded multilevel topology helps to improve the efficiency and flexibility of PV systems. To realize better utilization of PV modules and maximize the solar energy extraction, a distributed maximum power point tracking control scheme is applied to both single and three phase multilevel inverters, which allows independent control of each DC link voltage. For three phase grid connected applications, PV mismatches may introduce unbalanced supplied power, leading to unbalanced grid current. To solve this issue, a fuzzy logic control scheme with modulation Compensation is also proposed. A simulation three phase seven level cascaded H-bridge inverter has been built utilizing nine H- bridge modules (three modules per phase). Each H-bridge module is connected to a 185W solar panel. Simulation results are presented to verify the feasibility of the proposed approach.

I.INTRODUCTION

DUE to the shortage of fossil fuels and environmental problems caused by conventional power generation, renewable energy, particularly solar energy, has become very popular. Solar-electric-energy demand has grown consistently by 20%-25% per annum over the past 20 years [1], and the growth is mostly in grid-connected applications. With the extraordinary market growth in grid-connected photovoltaic (PV) systems, there are increasing interests in grid-connected PV configurations. Five inverter families can be defined, which are related to different configurations of the PV system: 1) central inverters; 2) string inverters; 3) multi string inverters; 4) ac-module inverters; and 5) cascaded inverters [2]-[7]. The configurations of PV systems are shown in Fig. 1. Cascaded inverters consist of several converters connected in series; thus, the high power and/or high voltage from the combination of the multiple modules would favour this topology in medium and large grid-connected PV systems [8]-[10]. There are two types of cascaded inverters. Fig. 1(e) shows a cascaded dc/dc converter connection of PV modules. Each PV module has its own dc/dc converter, and the modules with their associated converters are still connected in series to create a high dc voltage, which is provided to a simplified dc/ac inverter. This approach combines aspects of string inverters and ac- module inverters and offers the advantages of individual module maximum power point (MPP) tracking (MPPT), but it is less costly and more efficient than ac-module inverters. However, there are two power conversion stages in this configuration. Another cascaded inverter is shown in Fig. 1(f), where each PV panel is connected to its own dc/ac inverter, and those inverters are then placed in series to reach a high-voltage level.

This cascaded inverter would maintain the benefits of one converter per panel, such as better utilization per PV module, capability of mixing different sources, and redundancy of the system. In addition, this dc/ac cascaded inverter removes the need for the per-string dc bus and the central dc/ac inverter, which further improves the overall efficiency. The modular cascaded H-bridge multilevel inverter, which requires an isolated dc source for each H-bridge, is one dc/ac cascaded inverter topology. The separate dc links in the multilevel inverter make independent voltage control possible. As a result, individual MPPT control in each PV module can be achieved, and the energy harvested from PV panels can be maximized. Meanwhile, the modularity and low cost of

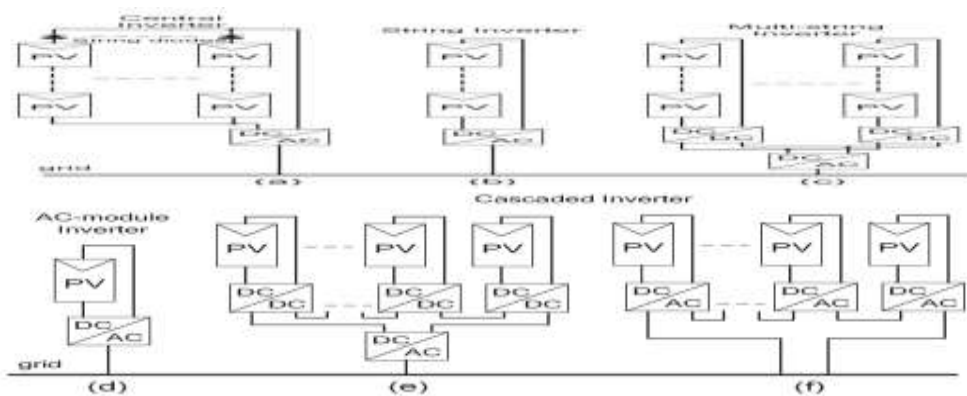

Fig. 1. Configurations of PV systems. (a) Central inverter.

(b) String inverter. (c) Multi string inverter. (d) AC-module inverter. (e) Cascaded dc/dc converter. (f) Cascaded dc/ac inverter.

A modular cascaded H-bridge multilevel inverter topology for single or three-phase grid-connected PV systems is presented in this paper. The panel mismatch issues are addressed to show the necessity of individual MPPT control with fuzzy logic, and a control scheme with distributed MPPT control is then proposed. The distributed MPPT and fuzzy control scheme can be applied to both single and three-phase systems. In addition, for the presented three-phase grid-connected PV system, if each PV module is operated at its own MPP, PV mismatches may introduce unbalanced power supplied to the three-phase multilevel inverter, leading to unbalanced injected grid current. To balance the three-phase grid current, modulation compensation is also added to the control system. A three-phase modular cascaded multilevel inverter prototype has been built. Each H-bridge is connected to a 185-W solar panel. The modular design will increase the flexibility of the system and reduce the cost as well. Simulation is provided to demonstrate the developed control scheme.

Advantages:

1. Less stress on individual switches
2. Less complexity
3. Easy maintained
4. High output voltage levels
5. Low THD

II. PHOTOVOLTAIC INVERTER

The PV power generation system consists of following major blocks:

1. PV unit
2. Inverter
3. Grid
4. MPPT

Analytical models are essential in the dynamic performance, robustness, and stability analysis of different control strategies. To investigate these features on a three-phase grid-connected PV system, the mathematical model of the system needs to be derived. The modeling of the proposed system includes:

1. Photovoltaic Cell and PV array Modeling
2. Three-phase inverter model
3. Three-phase fundamental transformations modeling

In this chapter, the operation and role of each of these components will be described and their mathematical model will be derived.

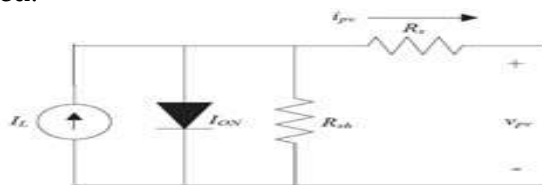

Fig.2. Equivalent circuit diagram of the PV cell

MPPT: (Maximum Power Point Tracking)

The P&O algorithm requires few mathematical calculations which makes the implementation of this algorithm fairly simple compared to other techniques. For this reason, P&O method is heavily used in renewable energy systems.

Perturb and Observe algorithm

At present, the most popular MPPT method in the PV systems is perturb and observe. In this method, a small perturbation is injected to the system and if the output power increases, a perturbation with the same direction will be injected to the system and if the output power decreases, the next injected perturbation will be in the opposite direction. The Perturb and observe algorithm operates by periodically perturbing (i.e. incrementing or decrementing) the array terminal voltage and comparing the PV output power with that of the previous perturbation cycle. If the PV array operating voltage changes and power increases, the control system moves the PV array operating point in that direction, otherwise the operating point is moved in the opposite direction. In the next perturbation cycle, the algorithm continues in the same way. The logic of algorithm is shown in Fig.2 A common problem in perturb and observe algorithm is that the array terminal voltage is perturbed every MPPT cycle, therefore when the maximum power point is reached, the output power oscillates around the maximum power point resulting in power loss in the PV system.

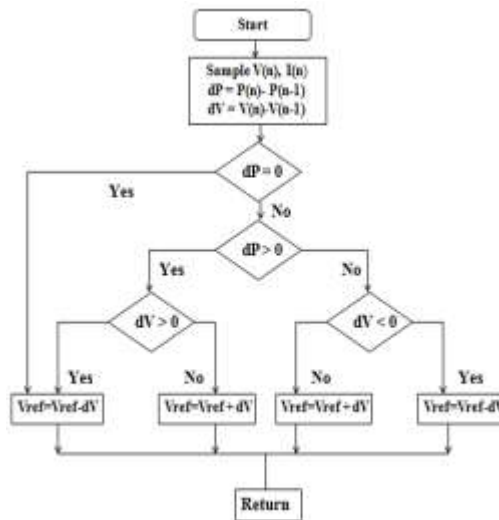

Fig.3.Flow chart of perturb and observe

1.FUZZY LOGIC

In recent years, the number and variety of applications of fuzzy logic have increased significantly. The applications range from consumer products such as cameras, camcorders, washing machines, and microwave ovens to industrial process control, medical instrumentation, decision-support systems, and portfolio selection. To understand why use of fuzzy logic has grown, you must first understand what is meant by fuzzy logic. The FIS Editor handles the high level issues for the system: How much input and output variables? What are their names? The Fuzzy Logic Toolbox doesn't limit the number of inputs. However, the number of inputs may be limited by the available memory of your machine. If the number of inputs is too large, or the number of membership functions is too big, then it may also be difficult to analyze the FIS using the other GUI tools. The Membership Function Editor is used to define the shapes of all the membership functions associated with each variable. The Rule Editor is for editing the list of rules that defines the behavior of the system. The following discussion walks you through building a new fuzzy inference system from scratch. If you want to save time and follow along quickly, you can load the already built system by typing fuzzy tipper This will load the FIS associated with the file tipper.fis (the .fis is implied) and launch the FIS Editor. However, if you load the pre-built system, you will not be building rules and constructing membership functions.

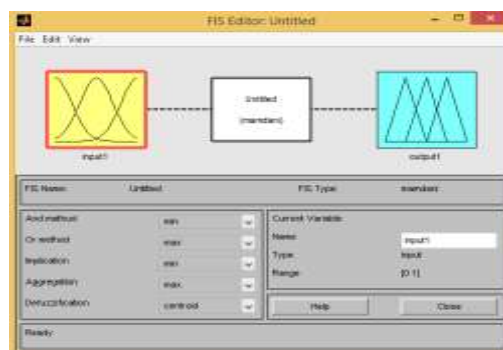

Fig.4. The FIS Editor

You will see the diagram updated to reflect the new names of the input and output variables. There is now a new variable in the workspace called tipper that contains all the information about this system.

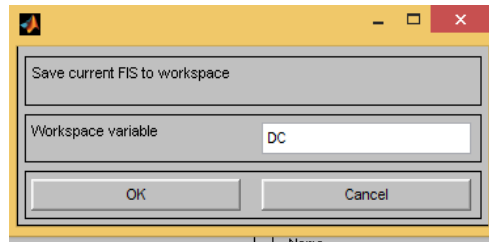

Fig.5 'Save to workspace as...' window

By saving to the workspace with a new name, you also rename the entire system.

The Membership Function Editor:



Fig.6 The Membership Function Editor

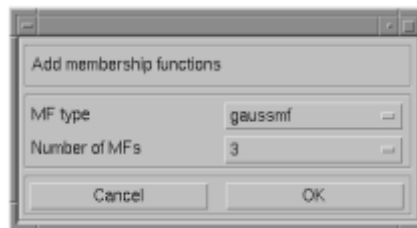

Fig.7 Add MFs. Window



Fig.8 The Updated Membership Function Editor

The Rule Editor:



Fig.9 The Rule Editor

	NB	NM	NS	ZE	PS	PM	PB
NB	NB	NB	NB	NB	NM	NS	ZE
NM	NB	NB	NB	NM	NS	ZE	PS
NS	NB	NB	NM	NS	ZE	PS	PM
ZE	NB	NM	NS	ZE	PS	PM	PB
PS	NM	NS	ZE	PS	PM	PB	PB
PM	NS	ZE	PS	PM	PB	PB	PB
PB	ZE	PS	PM	PB	PB	PB	PB

Fig 10 Fuzzy rules

III. PROJECT DESCRIPTION AND CONTROL SCHEME

Modular cascaded H-bridge multilevel inverters for single and three-phase grid-connected PV systems are shown in Fig. 2. Each phase consists of n H-bridge converters connected in series, and the dc link of each H-bridge can be fed by a PV panel or a short string of PV panels. By different combinations of the four switches in each H-bridge module, three output voltage levels can be generated: $-v_{dc}$, 0 , or $+v_{dc}$. A cascaded multilevel inverter with n input sources will provide $2n + 1$ levels to synthesize the ac output waveform. This $(2n + 1)$ -level voltage waveform enables the reduction of harmonics in the synthesized current, reducing the size of the needed output filters.

Panel Mismatches

PV mismatch is an important issue in the PV system. Due to the unequal received irradiance, different temperatures, and aging of the PV panels, the MPP of each PV module may be different. If each PV module is not controlled independently, the efficiency of the overall PV system will be decreased. To show the necessity of individual MPPT control, a five-level two-H-bridge single-phase inverter is simulated in MATLAB/SIMULINK. Each H-bridge has its own 185-W PV panel connected as an isolated dc source. The PV panel is modeled according to the specification of the commercial PV panel from a strong energy CHSM- 5612M. Consider an operating condition that each panel has a different irradiation from the sun; panel 1 has irradiance $S=1000$ W/m², and panel 2 has $S = 600$ W/m². If only panel 1 is tracked and its MPPT controller determines the average voltage of the two panels, the power extracted from panel 1 would be 133 W, and the power from panel 2 would be 70 W, as seen in Fig. 3. Without individual MPPT control, the total power harvested from the PV system is 203 W.

However, Fig. 4 shows the MPPs of the PV panels under the different irradiance. The maximum output power values will be 185 and 108.5 W when the S values are 1000 and 600 W/m², respectively, which means that the total power harvested from the PV system would be 293.5 W if individual MPPT can be achieved. This higher value is about 1.45 times of the one before. Thus, individual MPPT control in each PV module is required to increase the efficiency of the PV system. In a three-phase grid-connected PV system, a PV mismatch may cause more problems. Aside from decreasing the overall efficiency, this could even introduce unbalanced power supplied to the three-phase grid-connected system. If there are PV mismatches between phases, the input power of each phase would be different. Since the grid voltage is balanced, this difference in input power will cause unbalanced current to the grid, which is not allowed by grid standards. For example, to unbalance the current per phase more than 10% is not allowed for some utilities, where the percentage imbalance is calculated by taking the maximum deviation from the average current and dividing it by the average current [18]

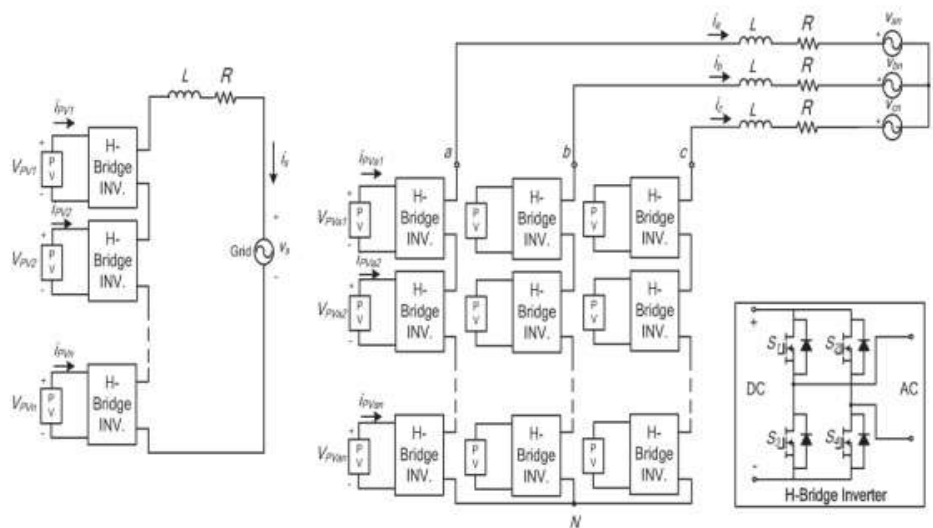

Fig.11. Topology of the modular cascaded H-bridge multilevel inverter for grid-connected PV systems.

To solve the PV mismatch issue, a control scheme with individual MPPT control and modulation compensation is proposed. The details of the control scheme will be discussed in the next section.

Control Scheme

Distributed MPPT Control

In order to eliminate the adverse effect of the mismatches and increase the efficiency of the PV system, the PV modules need to operate at different voltages to improve the utilization per PV module. The separate dc links in the cascaded H-bridge multilevel inverter make independent voltage control possible. To realize individual MPPT control in each PV module, the control scheme proposed in [19] is updated for this application. The distributed MPPT control of the three-phase cascaded H-bridge inverter is shown in Fig. 5. In each H-bridge module, an MPPT controller is added to generate the dc-link voltage reference.

Each dc-link voltage is compared to the corresponding voltage reference, and the sum of all errors is controlled through a total voltage controller that determines the current reference I_{dref} . The reactive current reference I_{qref} can be set to zero, or if reactive power compensation is required, I_{qref} can also be given by a reactive current calculator [20], [21]. The synchronous reference frame phase-locked loop (PLL) has been used to find the phase angle of the grid voltage [22]. As the classic control scheme in three-phase systems, the grid currents in abc coordinates are converted to dq coordinates and regulated through fuzzy logic with proportional-integral (PI) controllers to generate the modulation index in the dq coordinates, which is then converted back to three phases. The distributed MPPT control scheme for the single-phase system is nearly the same. The total voltage controller gives the magnitude of the active current reference, and a PLL provides the frequency and phase angle of the active current reference. The current loop then gives the modulation index. To make each PV module operate at its own MPP, take phase a as an example; the voltages $v_{dc a2}$ to $v_{dc a n}$ are controlled individually through $n - 1$ loops. Each voltage controller gives the modulation index proportion of one H-bridge module in a, $n - 1$ modulation indices can be obtained. Also, the modulation index for the first H-bridge can be obtained by subtraction. The control schemes in phases b and c are almost the same. The only difference is that all dc-link voltages are regulated through PI controllers, and n modulation index proportions are obtained for each phase

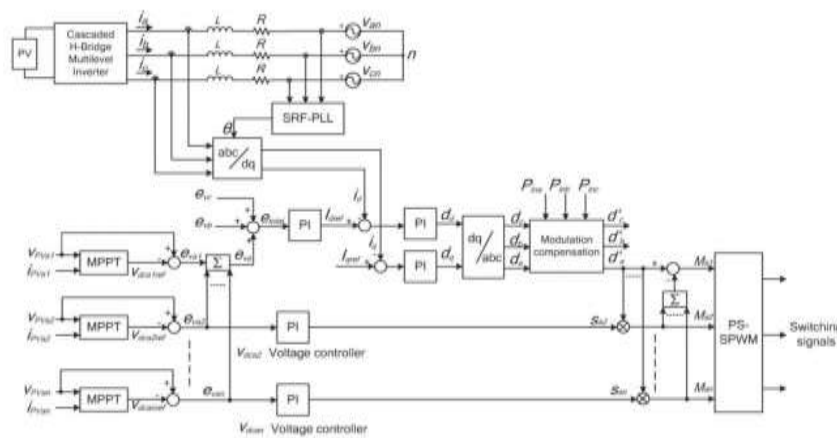

Fig.12. Control scheme for three-phase modular cascaded H-bridge multilevel PV inverter.

A phase-shifted sinusoidal pulse width modulation switching scheme is then applied to control the switching devices of each H-bridge. It can be seen that there is One H- Bridge module out of N modules whose modulation index is obtained by subtraction. For single-phase systems, $N = n$, and for three-phase systems, $N = 3n$, where n is the number of H-bridge modules per phase. The reason is that N voltage loops are necessary to manage different voltage levels on N H-bridges, and one is the total voltage loop, which gives the current reference. So, only $N - 1$ modulation indices can be determined by the last $N-1$ voltage loops, and one modulation index has to be obtained by subtraction. Many MPPT methods have been developed and implemented [23], [24]. The incremental conductance method has been used in this paper. It lends itself well to digital control, which can easily keep track of previous values of voltage and current and make all decisions.

A. Modulation Compensation

As mentioned earlier, a PV mismatch may cause more problems to a three-phase modular cascaded H-bridge multilevel PV inverter. With the individual MPPT control in each H-bridge module, the input solar power of each phase would be different, which introduces unbalanced current to the grid. To solve the issue, a zero sequence voltage can be imposed upon the phase legs in order to affect the current flowing into each phase [25], [26].

If the updated inverter output phase voltage is proportional to the unbalanced power, the current will be balanced. Thus, the modulation compensation block, as shown in Fig. 6, is added to the control system of three-phase modular cascaded multilevel PV inverters. The key is how to update the modulation index of each phase without increasing the

IV. SIMULATION RESULTS

Simulation test is carried out to validate the proposed ideas. A modular cascaded multilevel inverter simulation type has been built. The MOSFET is selected as inverter switches operating at 1.5 kHz. The control signals to the H-bridge inverters are sent by a fuzzy controller. A three phases even level cascaded H-bridge inverter is simulated. Each H- Bridge has its own 185W PV panel connected as an independent source. The inverter is connected to the grid through a transformer, and the phase voltage of the secondary side is 60 Vrms. The system parameters are shown in Table 12. To verify the proposed control scheme, the three phase grid connected PV inverter is simulated in two different conditions. First, all PV panels are operated under the same irradiance $S = 1000 \text{ W/m}^2$ and temperature $T = 25 \text{ }^\circ\text{C}$. At $t = 0.8 \text{ s}$, the solar irradiance on the first and second panels of phase a decreases to 600 W/m^2 , and that for the other panels stays the same. The DC link voltages of phase a are shown in Fig. 16.

At the beginning, all PV panels are operated at an MPP voltage of 36.3 V. As the irradiance changes, the first and second dc link voltages decrease and track the new MPP voltage of 35.9 V, while the third panel is still operated at 36.3 V. The PV current waveforms of phase a are shown in Fig. 18. After $t = 0.8 \text{ s}$, the currents of the first and second PV panels are much smaller due to the low irradiance, and the lower ripple of the DC link voltage can be found in Fig. 16. The DC link voltages of phase b are shown in Fig. 18(b). All phase b panels track the MPP voltage of 36.3 V, which shows that they are not influenced by other phases. With the distributed MPPT control, the DC link voltage of each H-bridge can be controlled independently. In other words, the connected PV panel of each H-bridge can be operated at its own MPP voltage and will not be influenced by the panels connected to other H-bridges.

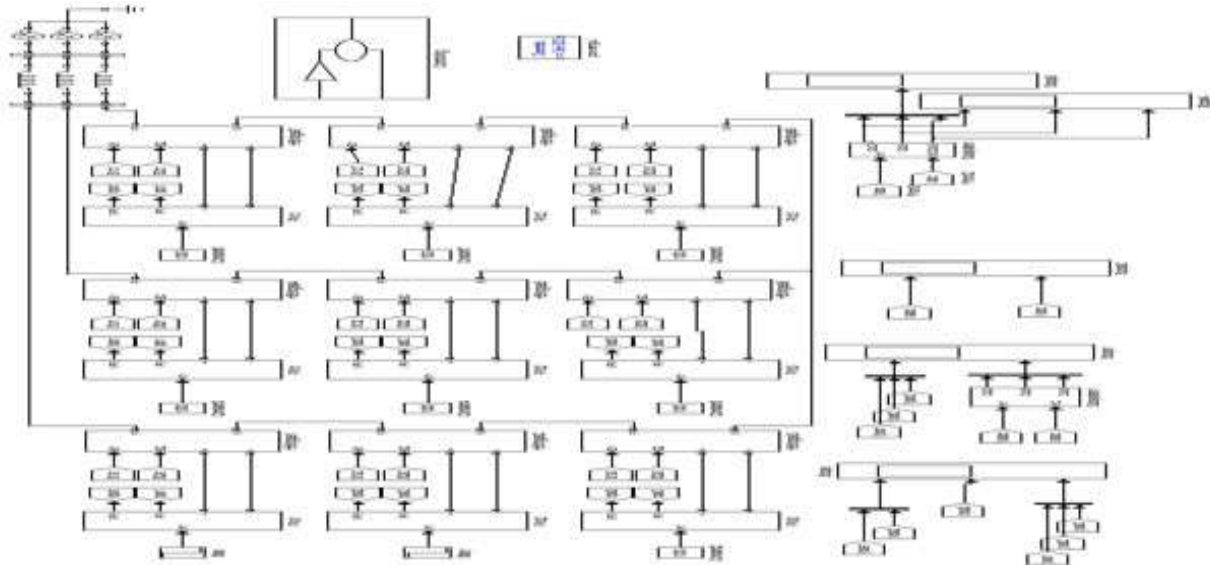

Fig.13.Proposed simulation diagram

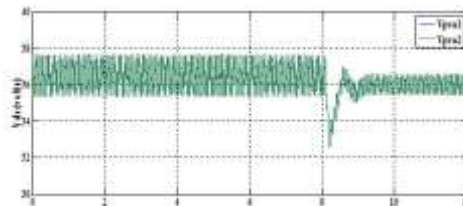

Fig.19.DC link voltages of phase a with distributed MPPT ($T= 25^{\circ}\text{C}$)

v. CONCLUSION

In this paper, a modular cascaded H-bridge multilevel inverter for grid connected PV applications has been presented by using fuzzy logic controller. The multilevel inverter topology will help to improve the utilization of connected PV modules if the voltages of the separate DC links are controlled independently. Thus, a distributed MPPT control scheme with fuzzy logic for both single phase and three phase PV systems has been applied to increase the overall efficiency of PV systems. For the three phase grid connected PV system, PV mismatches may introduce unbalanced supplied power, resulting in unbalanced injected grid current. A modulation compensation scheme, which will not increase the complexity of the control system or cause extra power loss, is added to balance the grid current. A modular three phase seven level cascaded H-bridge inverter has been built in the laboratory and tested with PV panels under different partial shading conditions. With the proposed fuzzy with MPPT control scheme, each PV module can be operated at its own MPP to maximize the solar energy extraction, and the three phase grid current is balanced even with the unbalanced supplied solar power.

REFERENCES

- [1] J. M. Carrasco et al., -Power-electronic systems for the grid integration of renewable energy sources: A survey,|| IEEE Trans. Ind. Electron., vol. 53, no. 4, pp. 1002-1016, Jun. 2006.
- [2] S. B. Kjaer, J. K. Pedersen, and F. Blaabjerg, -A review of single-phase grid connected inverters for photovoltaic modules,|| IEEE Trans. Ind. Appl., vol. 41, no. 5, pp. 1292- 1306, Sep./Oct. 2005.
- [3] M. Meinhardt and G. Cramer, -Past, present and future of grid connected photovoltaic- and hybrid power-systems,|| in Proc. IEEE PES Summer Meet., 2000, vol. 2, pp. 1283- 1288. [4] F. Schimpf and L. Norum, -Grid connected converters for photovoltaic, state of the art, ideas for improvement of transformerless inverters,|| in Proc. NORPIE, Espoo, Finland, Jun. 2008, pp. 1-6.
- [5] B. Liu, S. Duan, and T. Cai, -Photovoltaic DC-building- module-based BIPV system – Concept and design considerations,|| IEEE Trans. Power Electron., vol. 26, no. 5, pp. 1418-1429, May
- [6] L. M. Tolbert and F. Z. Peng, –Multilevel converters as a utility interface for renewable energy systems,|| in Proc. IEEE Power Eng. Soc. Summer Meet., Seattle, WA, USA, Jul. 2000, pp. 1271-
- [7] H. Ertl, J. Kolar, and F. Zach, –A novel multicell DC- AC converter for applications in renewable energy systems,|| IEEE Trans. Ind. Electron.,vol. 49, no. 5, pp. 1048-1057, Oct. 2002.
- [8] S. Daher, J. Schmid, and F. L. M. Antunes, -Multilevel inverter topologies for stand-alone PV systems,|| IEEE Trans. Ind. Electron., vol. 55, no. 7,pp.2703-2712.